

ROSTHERNE BATH INSTALLATION GUIDE

The Rostherne is supplied with the following components:-

Bath with 8 Loose Feet
Front Panel & optional End Panel
Single Waste kit
2 x Wall fixing brackets
Optional Towel & Grab Rail

CONTOUR
built-in independence

Other Items required with contract

Thermostatic Valve (MUST BE INSTALLED IN ALL CASES)

Possible additional items:

Pump and flow switch. (Refer to Installation notes)

Bath/shower mixer/taps. (Refer to Installation notes.)

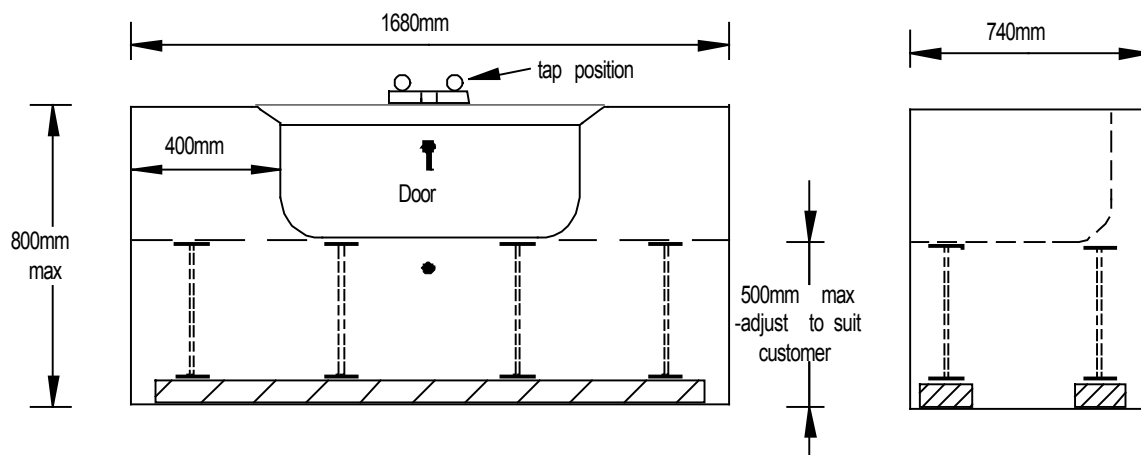

IMPORTANT NOTES

The Rostherne bath is no different from any other standard bath with regards to services and installation. It is installed at a raised level to allow the door to be dropped down & provide a ledge for the customer to sit on before entering the bath.

Door is opened by turning Lock Lever on door face in either direction. Hold door when opened as it is not supported when it folds downwards. Slam shut firmly to close.

The bath has a water capacity of 196 litres (unoccupied) which may require pump assisted taps with a flow rate of 17 litres/min minimum. Use only 22mm pipe leads to enhance flow rate. Bath is filled only when user has entered and door shut consequently taps must be thermostatically controlled.

The eight supporting legs must all be installed to provide bath stability and adjusted in height to customer's satisfaction.

The bath should be installed rigidly to ensure there will be no movement or sagging of the floor when bath is used. If fitting in an alcove ensure the bath freely goes into position (as sideways pressure can distort the doorway).

- ◆ The Rostherne is manufactured in glass fibre. When handling, proceed with care and caution, in particular the bath edges are more brittle than in acrylic baths.

Wet Rooms Direct

Telephone: 01685 898110

Email: sales@wetroomsdirect.net Website: www.wetroomsdirect.net

STANDARD FITTING GUIDE

- 1) Ensure area for the Rostherne bath is cleared and any prior works to walls, floor and pipe work are adequately prepared before moving bath into position. **DO NOT** conduct works in close proximity to bath without adequate protection to bath surfaces.
 - 2) Drill and affix taps to center of bath back rim. Fit waste and overflow.
 - 3) Fit the 8 legs loosely onto bath and adjust to appropriate height for customer (500mm max.).
It is important to fix batten runs on to the floor under the bath feet to avoid extending the legs to far & to ensure feet sit squarely and flat. Use 2" x 1" (min) for concrete floor. On a wooden floor batten runs (3" x 2" (min)) should be positioned squarely across the floor boards to spread & support the load.
 - 4) Place bath into position and confirm customers ability to safely sit and rise up from doorway without undue exertion. Fine adjust bath height to suit customer accordingly.
 - 5) Level bath by means of the four outer corner legs only. Do not level with the four inner legs as this might distort bath and affect bath seal.
 - 6) Mark up wall fixings on furthest ends as appropriate (via 2 x bath fixing brackets supplied loose) and plumbing run.
 - 7) Remove bath, drill wall fixings and run plumbing into position.
 - 8) Reposition bath and affix to wall and to floor via brackets and bath feet. Affix the four corner legs firmly into position. The four inner legs are for added support only and should be relatively loose in comparison.
 - 9) Connect all plumbing following standard good practice procedures for the thermostatic valve (refer to installation guide). Fix the Shower Park in position to suit customer.
 - 10) Test all plumbing for leaks. Fill bath full to overflow and leave for 30 minutes to test bath seal. On completion check overflow and waste for leaks when draining .
 - 11) Whilst bath seal is tested (as above) measure up front and side panels (side panels are handed) and trim down to required length. Offer up top side of panels to lip over bath rim. Position accordingly and mark bottom of panels onto floor base. Fix battens along floor behind side panels.
 - 12) Refit side and front panels. Drill through bottom of panels into battens and secure with screws and caps.
 - 13) Seal bath rim adjoining walls/furniture and make good installation.
 - 14) Finally drain bath and Leave The Door Folded Down in the Open Position to prevent over compression and the wear out of the seal.
- ◆ Instruct customer on the use of the bath and leave copy of the user guide with the customer.
 - ◆ Do not leave door in locked position on completion. Advise customer that the door should be left folded down/open when not in use in order to preserve the seal.

Wet Rooms Direct

Telephone: 01685 898110

Email: sales@wetroomsdirect.net Website: www.wetroomsdirect.net

THE ROSTHERNE BATH

IMPORTANT INSTRUCTIONS FOR CUSTOMER

**PLEASE READ CAREFULLY AND RETAIN FOR FURTHER USE.
IMPROPER USE OR CARE CAN INVALIDATE THE WARRANTY.**

OPERATING INSTRUCTIONS

The Rosthenre Bath features a watertight door which is held in a locked position by means of two latch locks on the LHS and RHS of doorway sides. The locks are released by means of the Lock Lever on face of door.

Always leave door in an open folded down position when bath is not in use. This is to prevent over compression & wearing out of the door rubber seal.

1. Approach bath and sit on doorway ledge on far left hand side or right hand side as is preferable. Lift legs over into bath and push back towards bath end side.
2. Firmly hold Door Grip on the inner face of door and pull over to slam shut door ensuring locks are engaged on both sides. If lock furthest away has not engaged pull on Door Grip again whilst still in this position.
3. The bath is now watertight and ready for use.
4. After bathing, remain in bath until all the water is drained on release of the bath waste.
5. Turn door Lock Lever on front face of door (in either direction) to release locks whilst holding Door Grip on inner face. Carefully lower door down to a fully open position before letting go of Grip.
6. Exit the bath and leave the door folded down in an open position.

- NEVER ATTEMPT TO OPEN DOOR WHEN BATH IS FILLED WITH WATER
- DO NOT LEAN ON DOOR OR USE FOR SUPPORT EXCESSIVELY

CARE AND MAINTENANCE

The Rostherne Bath is manufactured to a very high standard in G.R.P. (Reinforced Plastic) to ensure its durability and appearance is maintained over many years of use. It has a robust, smooth and warm surface, which is non-porous, resistant to dirt and bacteria and easy to clean and maintain.

The Rostherne bath will give many years of service and continue to look good if cleaned correctly and treated with care.

CLEANING

1. As with standard baths, cleaning will vary subject to the scale residue dependant on the hard or soft water level. In soft water areas, wash down with warm water and detergent applied with a soft cloth or sponge. In hard water areas, non-abrasive or mild acid cleansers can be used. Clean regularly followed by wiping with a dry soft cloth.

Widely available proprietary plastic/enamel bath cleansers are ideal cleaning agents which offer the advantage of a polished shine without rubbing down.

For the extra sparkle, and to further preserve the surface, the Bath can be gently polished occasionally. Beeswax and Brasso (Brass Polish) are suitable for this purpose.

2. Lubricate and polish door latch locks at least once a year (subject to the chlorine content in the water). A standard lubricant such as “WD 40” or “3 in 1 oil” would be adequate.
3. The white silicone seal along bath door sides must be cleaned occasionally to ensure no build up of foreign deposits. Use detergent and warm water applied with a sponge or soft cloth. Apply gently and refrain from excessive rubbing.
4. All chrome or gold plated furniture should be wiped down dry after use. Clean with soapy water and buff with a dry soft cloth. Note: Surfaces can easily be damaged by acid, abrasive detergent or rough sponge.

CAUTION

- **LEAVE DOOR IN OPEN/FOLDED DOWN POSITION WHEN BATH IS NOT IN USE TO PRESERVE THE SEAL.**
- **KEEP THE WHITE SILICONE SEAL FREE OF ANY BUILD UP OF DEPOSITS. CLEAN GENTLY AND AVOID UNNECESSARY HANDLING.**
- **DO NOT APPLY ANY UNDUE FORCE TO THE BATH DOOR. ALWAYS HANDLE AND SUPPORT DOOR WHEN OPENING.**

